



TBC- BR series current sensor is a closed loop device based on the measuring principle of the hall effect and null balance method, with a galvanic isolation between primary and secondary circuit. It provides accurate electronic measurement of DC, AC or pulsed currents.

Electrical data (Ta=25°C±5°C)

Type Parameter	TBC50 BR	TBC100 BR	TBC200 BR	TBC300 BR	Unit
Rated input (I _{pn})	±50	±100	±200	±300	A
Measure range (I _p)	±150 (±18V,90Ω)	±300 (±18V,30Ω)	±600 (±18V,20Ω)	±900 (±18V,5Ω)	A
Turns ratio (N _p /N _s)	1:1000	1:1000	1:2000	1:3000	T
Rated output (I _{sn})	50±0.5%	100±0.5%	100±0.5%	100±0.5%	mA
Coil resister @70°C	20	20	30	50	Ω
Measure resister	2 ~ 50				Ω
Supply voltage	±12 ~ ±18				V
Power consumption	≤20+I _p X (N _p /N _s)				mA
Zero offset	@I _p =0	≤±0.15			mA
Zero drift	≤±0.4				mA
Linearity	@I _p =0-±I _{pn}	≤0.1			%FS
Band-width	@-3dB	DC-200			KHz
Response time	@100A/μS,10%-90%	≤1			μS
Galvanic isolation	@ 50HZ, AC,1min	3			KV

Applications

- AC variable speed drives
- Static converters for DC motor drives
- Variable speed drives
- Power supplies for welding applications
- Battery supplied applications
- Uninterruptible Power Supplies (UPS)
- Switched Mode Power Supplies (SMPS)

Mechanical dimension (for reference only)

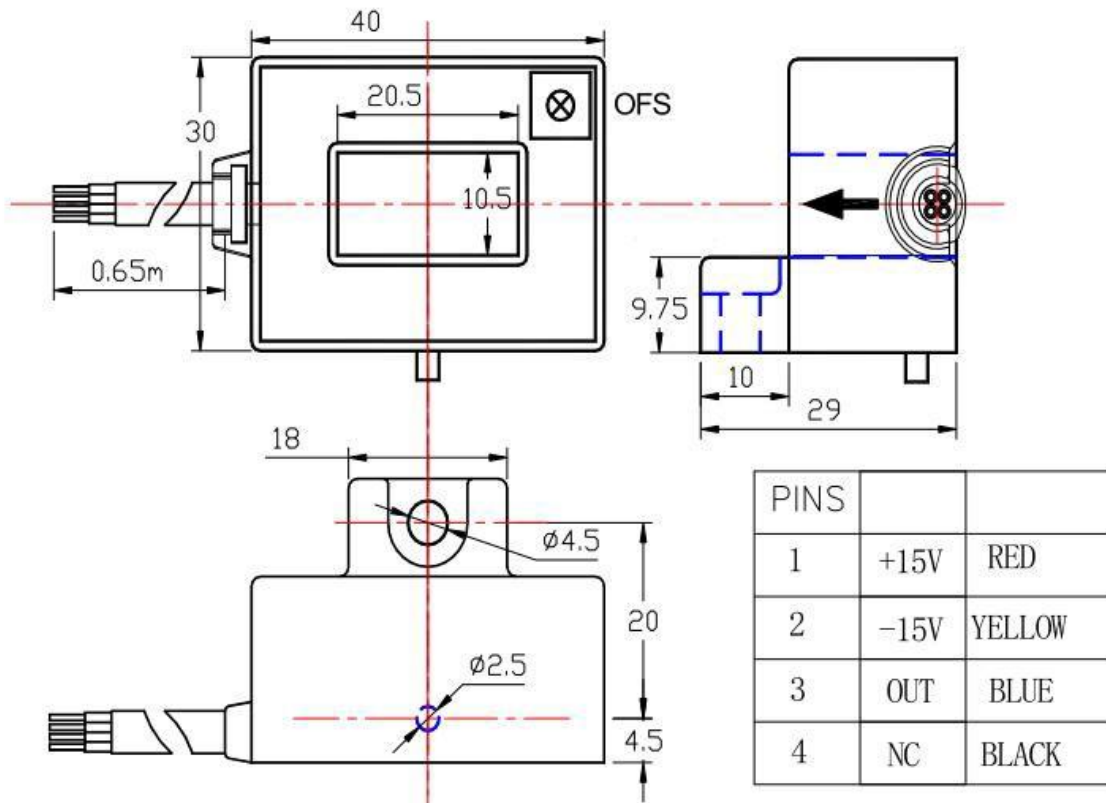

Remarks :

1. All dimensions are in mm.
2. General tolerance $\pm 1\text{mm}$.

Directions for use

1. When measure current flows according to the direction of the arrowhead, Output terminal gets the same phase current.
2. When the current will be measured goes through a sensor, the current will be measured at the output end.
(Note: The false wiring may result in the damage of the sensor)
3. Custom design in the different rated input current and the output current are available.

Standards

UL94-V0
 EN60947-1:2004
 IEC60950-1:2001
 EN50178:1998
 SJ 20790-2000

General data

	Value	Unit	Symbol
Operating temperature	-40 to +85	°C	TA
Storage temperature	-40 to +125	°C	TS
Mass(approx)	58	g	M

Characteristics chart

Pulse current signal response characteristic

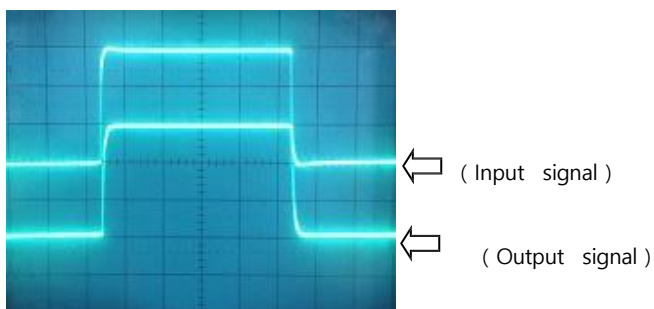

Effects of impulse noise

